

FEATURES Lithium Iron Phosphate (LiFePO₄): the Safest Lithium Technology.

Integrated Battery Management System(BMS).
Bluetooth/Heater/LCD Indicator(Optional).

PERFORMANCE Long Cycle Life>4000cycles @80% DOD.

High Density, High Discharge Current,
High Temperature Range.Low Weight,
Free Maintenance.
Fast Charging.
Environment Friendly.



CP12100(12.8V100Ah)

BATTERY DATA SHEET

Electrical Parameters

Nominal Voltage	12.8V
Rated Capacity	100Ah
Energy	1280Wh
Resistance	≤30m Ω
Efficiency	99%
Cycle Life	>4000cycles @0.2C,80% DOD
Self Discharge	3% per Month
Max. Modules in Series/Parallel	4S/4P

Mechanical Parameters

Dimension(L x W x H)	329x 172x 215 mm 13.0 x 6.7 x 8.4"
Weight	14.60kg(32.2 lbs)
Terminal Type	M8
Battery Housing	ABS
Housing Protection	IP66
Cell Type-Chemistry	LiFePO ₄ Cylindrical Cell
SOC Display(Optional)	LCD Indicator

Discharge Parameters

Continuous Discharge Current	150A
Pulse Discharge Current	200A(5 seconds)
Recommended Volt. Disconnect	11V
BMS Discharge Cut-off Voltage	8V
Reconnect Voltage	9.2V
Short Circuit Protection	200~600 us

Charge Parameters

Charge Method	CC-CV
Charge Voltage	14.4~14.8V
Recommended Float Voltage	13.8V
Recommended Charge Current	50A
Maximum Charge Current	100A
BMS Charge Cut-off Voltage	15.6V

Compliance Certificate

Certifications	UL1642(Cell)
	CE
	IEC62133 & CB
	MSDS
	TÜV
Shipping Classification	UN3480, Class 9, UN38.3

Temperature Parameters

Discharge Temperature	-20 to 60°C (-4 to 140°F)
Charge Temperature	5 to 45°C (41 to 113°F)
Storage Temperature	-40 to 60°C(-40 to 140°F)
BMS High Temperature Cut-off	80°C(176°F)



Performance Charateristics

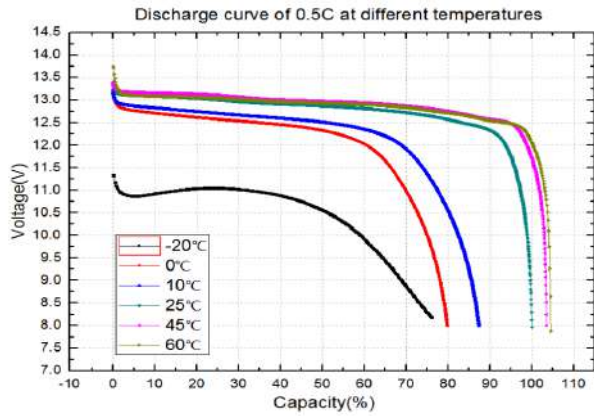
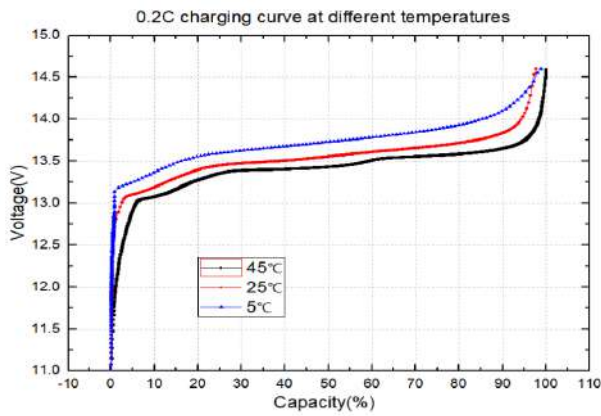
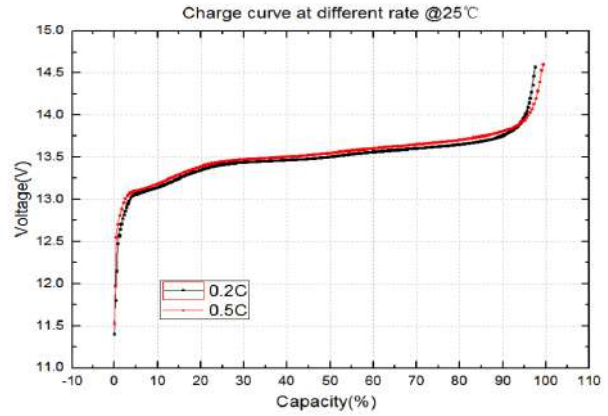
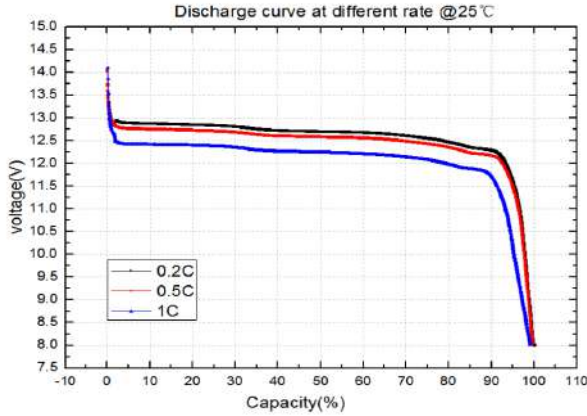

Battery Dimension

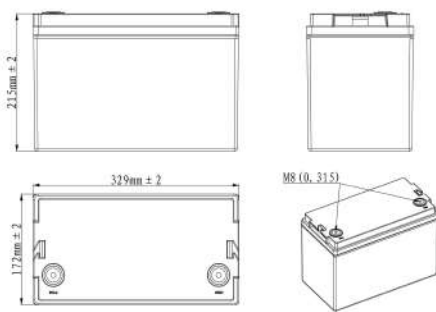

Battery Recycle



Battery Applications

- + Data Center UPS
- + Telecom Backup Power
- + Military Power Supply
- + Solar Energy Storage System
- + Solar Street LED Lightings
- + Autonomously Guided Vehicles (AGVs)
- + Industrial Robotics & Handling Equipment
- + Aerial Work Platform
- + Floor Cleaning Machines
- + Power Tools, Lawn Mower
- + Electric Bike & Motorcycles
- + Electric Mobilities (E-scooters, Wheelchair)
- + Golf Trolley & Golf Carts
- + Medical Devices
- + Electric Ships
- + Passenger Vehicles

NOTE: Do Not Mix With Sealed Lead Acid Batteries When Recycling.